

Product Information

General

Name:	LL-ME-24-26/0,9Nm RB32 VRS
Article number:	01070050
OEM or STANDARD:	Standard
Application:	Roller blind

Product photo:



Product label:

Lovoline® LL-ME-24-26/0,9Nm RB32 VRS

Art.-no.: 01070050	0,9 Nm	Ø 26 mm
24 V	30 rpm	14180004
12 W	0,5 A	IP 20
		868 MHz

1314_01070050_LAB

Vestamatic³
 Dohrweg 27
 41066 Mönchengladbach
 Germany

64_2.1.0.5

1418C

Dimensions:

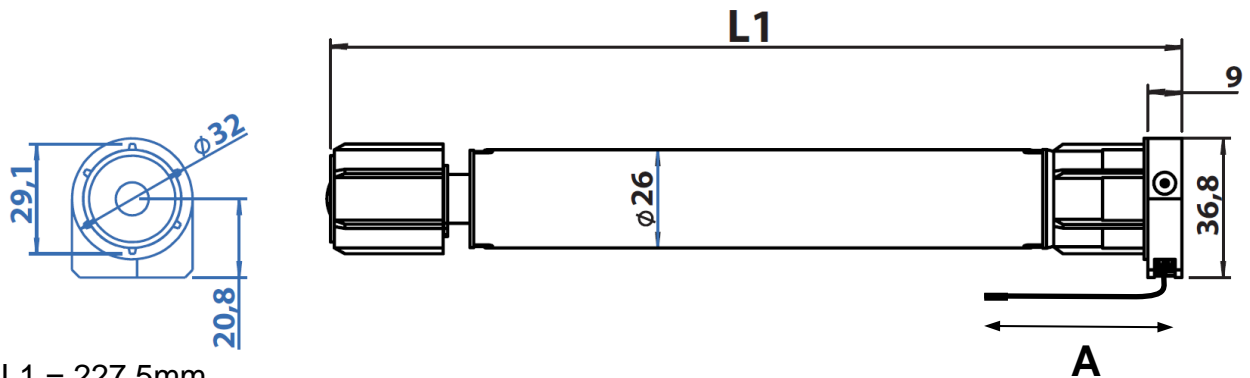

L1 = 227,5mm
 A = 65mm

Specifications:

Supply voltage range:	22 – 28VDC
Supply voltage (recommended):	24VDC
Impulse voltage withstand level:	500 V
Rated power (idle):	0.2 W ¹⁾
Rated power (nominal):	6 W ¹⁾
Rated power (maximum):	12 W ¹⁾
Torque (nominal):	65 Ncm
Torque (maximum):	90 Ncm
Maximum on time:	10 min. at +25 °C (77 °F) ambient temperature
Speed:	5 – 30 rpm
Software class:	A
Operating temperature:	-10 °C (14 °F) to +85 °C (185 °F)
IP class:	IP 20
Degree of contamination:	2
Dimensions (L x B x H):	227,5 x 32 x 36,5 mm
Conformity:	CE
Radio frequency:	868 MHz

¹⁾ At recommended supply voltage.

How to connect:

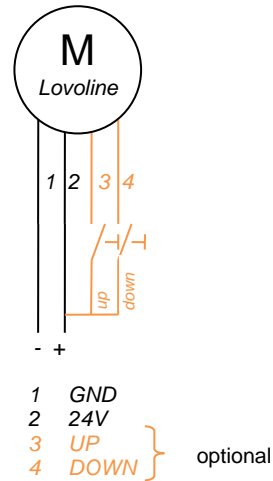
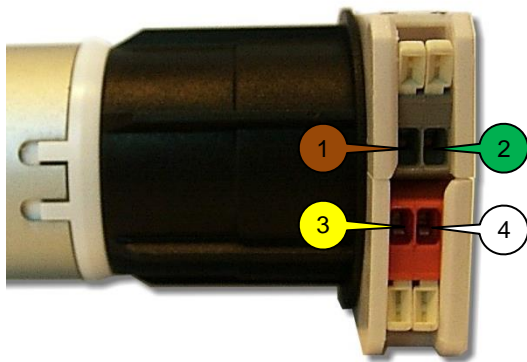

How to set upper and lower limit position

Installation

The upper and lower limit positions of the Lovoline RB motor can be set in different order. Following overview shows how the motor will react for the different scenarios:

Set upper limit position first

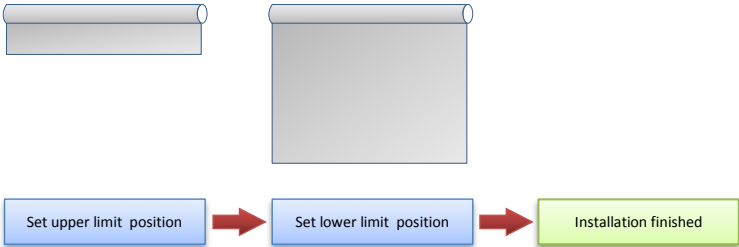

Set lower limit position first

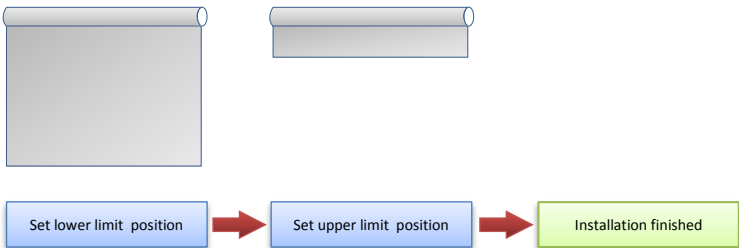

How to connect the Installation tool

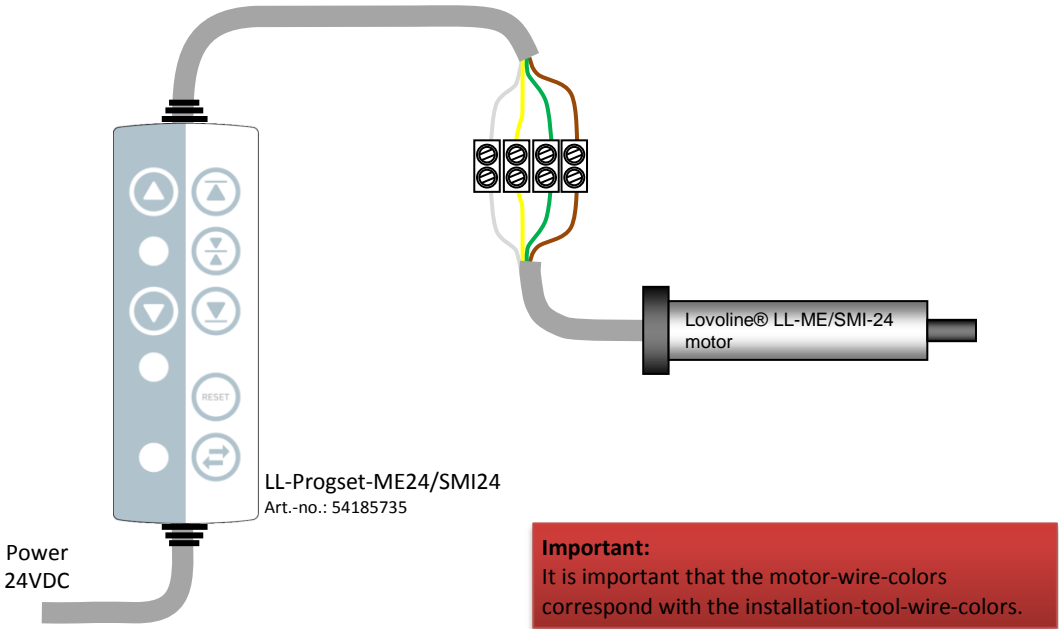



Installation tool in detail

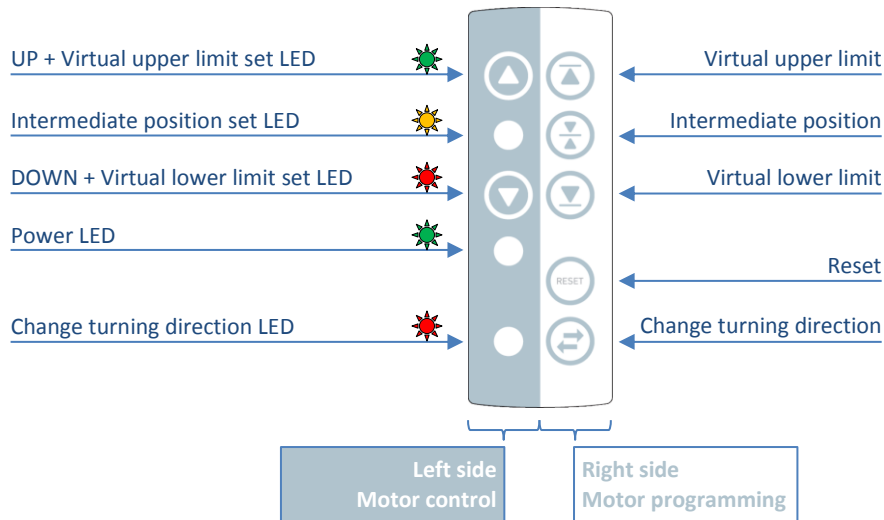

Motor control

Button Control motor in UP direction.
When the motor moves DOWN, when pressing the UP button, the turning direction of the motor should be corrected by pressing change motor direction button.

LED Virtual upper limit position LED:
Off when no "Virtual upper limit" is set.
Blinking when "Virtual upper limit" or "Reset" programming is in progress.
Lit solid when virtual upper limit programming sequence has completed.

Button -
LED Intermediate position LED:
Off when no "Intermediate position" is set.
Blinking when "Intermediate position" or "Reset" programming is in progress.
Lit solid when Intermediate position programming sequence has been completed.

Button Control motor in DOWN direction.
When the motor moves UP, when pressing the DOWN button, the turning direction of the motor should be corrected by pressing change motor direction button.

LED Virtual lower limit position LED:
Off when no "Virtual lower limit" is set.
Blinking when "Virtual lower limit" or "Reset" programming is in progress.
Lit solid when virtual lower limit programming sequence has completed.

Button -
LED Power LED:
Off when powerless (it is safe to connect a motor to the Installation Tool).
Blinking when connected motor is running.
Lit solid when attached to power supply (motor idle or not connected).

Button -
LED Change turning direction LED:
Blinking when "Change turning direction" is in progress.
Lit solid when "Change turning direction" programming sequence has completed.

Motor programming

Button Set virtual upper limit position.
LED -

Button Set intermediate position
(only valid when ULP and LLP are set).
LED -

Button Set virtual lower limit position.
LED -

Button Reset.
LED -

Button Change motor turning direction.
LED -



Motor reset

Motor reset will erase the limit positions. The motor turning direction and obstacle detection status will be left unchanged.



Description

To [reset the motor settings](#) (erase limit positions and intermediate position), the reset button must be pressed more than 3 seconds.

- 1 Press the [reset](#) button, till the virtual upper limit LED and virtual lower limit LED start blinking.
- 2 The virtual upper limit LED and virtual lower limit LED keep blinking as long as the motor [reset](#) process is in progress.
- 3 When the [reset](#) process is finished, virtual upper limit LED and virtual lower limit LED turn off, the motor limit positions have been cleared, and can be set again. The motor will give a short confirmation (short UP – STOP – DOWN – STOP movement)

Remark

The motor can shortly move during the [reset](#) sequence. This is normal.



Changing motor turning direction

When the motor reacts in opposite direction (when motor goes down when you press up and vice-versa), you need to change the motor direction. Motor direction can only be changed during installation phase, when no limit positions are set.



Description

- 1 Press the [change motor turning direction](#) button shortly.
- 2 The [change motor turning direction LED](#) starts blinking as long as the [change motor turning direction](#) process is in progress.
- 3 When the [change motor turning direction](#) process is finished, the [change motor turning direction LED](#) turns off, the motor turning direction is changed. The motor will give a short confirmation (short UP – STOP – DOWN – STOP movement)

Now, when operating the motor you will notice that the motor reacts in the correct direction in relation to your installation tool (motor goes up when you press up and vice-versa).



Setting upper virtual limit position

This sequence will store the current motor position as a virtual upper limit position.



Description

- 1 Press the [virtual upper limit](#) button shortly.
- 2 The [virtual upper limit LED](#) start blinking as long as the [set-virtual-upper-limit](#) process is in progress.
- 3 When the [set-virtual-upper-limit](#) process is finished, the [virtual upper limit LED](#) lit solid, the motor upper virtual limit position is set. The motor will give a short confirmation (short UP – STOP – DOWN – STOP movement)



Setting lower virtual limit position

This sequence will store the current motor position as a virtual lower limit position.



Description

- 1 Press the **virtual lower limit** button shortly.
- 2 The **virtual lower limit LED** start blinking as long as the **set-virtual-lower-limit** process is in progress.
- 3 When the **set-virtual-lower-limit** process is finished, the **virtual lower limit LED** lit solid, the motor lower virtual limit position is set. The motor will give a short confirmation (short UP – STOP – DOWN – STOP movement)



Setting intermediate position

This sequence will store the current motor position as intermediate position. Before setting the intermediate position, the upper and lower limit position should be set and confirmed.



Description

- 1 Press the **intermediate position** button shortly.
- 2 The **intermediate position LED** start blinking as long as the **set-intermediate-position** process is in progress.
- 3 When the **set-intermediate-position** process is finished, the **intermediate position LED** lit solid, the motor intermediate position is set. The motor will give a short confirmation (short UP – STOP – DOWN – STOP movement)



Radio Ergonomics

The Lovoline VRS motor is equipped with a radio module. The radio ergonomics shows a great similarity with the Switch ergonomics.



Teach remote control - FB5

This procedure will *link* a FB5 remote control with the motor.

Preparation

The used remote control must be set to the correct channel.

Description

- 1) Activate the motor *learn* mode by:
 - a. Power-on motor as described in *How to connect*. After power-on, the motor accepts *Remote Control Teach* messages for a period of 60 seconds.

or

 - b. With an remote control that is already *bound* to the motor, press the PROGRAM button on the back of this remote, next press the STOP button (FB5) or UP or DOWN briefly (Wall transmitter). The motor will a short confirmation (1x short up/down movement). The motor accepts *Remote Control Teach* messages for a period of 10 seconds.
- 2) Press the Program button on the back of the (to be added) FB5 remote control once (use pen or pencil to press Program button).

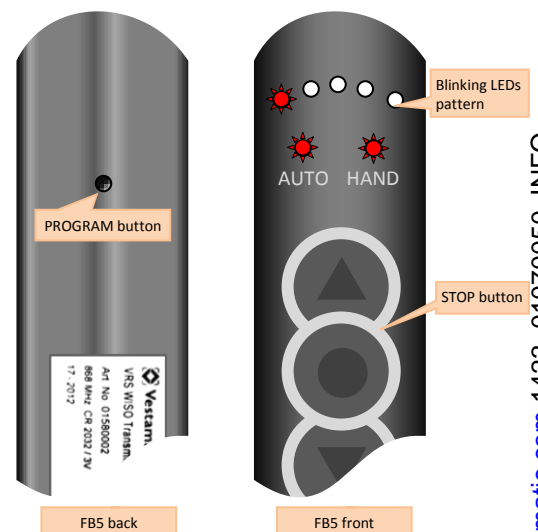

- 3) LEDs on the front of the FB5 show blinking pattern.
- 4) Press STOP briefly (on the to be added FB5 remote).
- 5) Motor will give a short confirmation (2x short up/down movement) that the remote control has been added to the list.

When **no** confirmation is given by the motor, possible causes:

- a. Motor did not receive the “Teach” command correctly, or
- b. Remote control receiver list is full. Maximum 16 devices can be taught to a motor.

Limitations

A maximum of 16 different remotes controls/channels/sensors can be taught.

Teach remote control – Wall transmitter

This procedure will “link” a wall transmitter (VRS Switch 1 / VRS Switch 2) with the motor.

Description

- 1) Activate the motor “learn” mode by:
 - a. Power-on motor as described in “How to connect”. After power-on, the motor accepts “Remote Control Teach” messages for a period of **60** seconds.

or

 - b. With an remote control that is already “bound” to the motor, press the PROGRAM button on the back of this remote, next press the STOP button (FB5) or UP or DOWN briefly (Wall transmitter). The motor will a short confirmation (1x short up/down movement). The motor accepts “Remote Control Teach” messages for a period of **10** seconds.
- 2) Press the Program button on the back of the (to be added) wall transmitter once.
- 3) The LED next to Program button starts blinking slowly.
- 4) Press UP or DOWN button of desired channel briefly (on the to be added wall transmitter).
- 5) Motor will give a short confirmation (2x short up/down movement) that the remote control has been added to the list.

When **no** confirmation is given by the motor, possible causes:

- a. Motor did not receive the “Teach” command correctly, or
- b. Remote control receiver list is full. Maximum 16 devices can be taught to a motor.

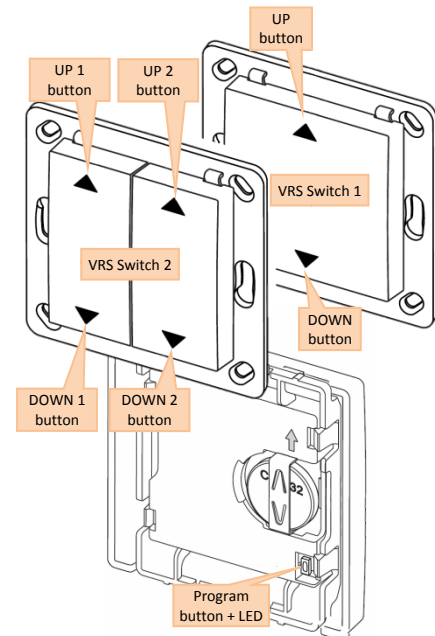

Limitations

A maximum of 16 different remotes controls/channels/sensors can be taught.

Teach sensor – VRS Luxsensor S

This procedure will “link” a VRS Luxsensor S with the motor.

Description

- 1) Activate the motor “learn” mode by:
 - a. Power-on motor as described in “How to connect”. After power-on, the motor accepts “Remote Control Teach” messages for a period of **60** seconds.

or

 - b. With an remote control that is already “bound” to the motor, press the PROGRAM button on the back of this remote, next press the STOP button (FB5) or UP or DOWN briefly (Wall transmitter). The motor will a short

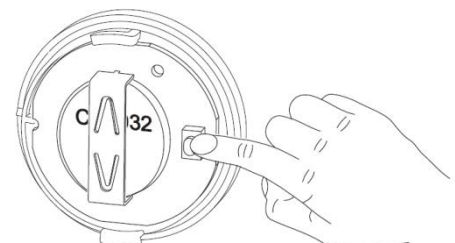

confirmation (1x short up/down movement). The motor accepts “Remote Control Teach” messages for a period of 10 seconds.

- 2) Press the Program button on the back of the VRS Luxsensor S once.
- 3) Motor will give a short confirmation (2x short up/down movement) that the remote control has been added to the list.

When **no** confirmation is given by the motor, possible causes:

- a. Motor did not receive the “Teach” command correctly, or
- b. Remote control receiver list is full. Maximum 16 devices can be taught to a motor.

Limitations

A maximum of 16 different remotes controls/channels/sensors can be taught.

Forget remote control - FB5 or Wall transmitter

This procedure will “unlink” a FB5 remote control from the motor.

Description

- 1) Activate the motor “forget” mode with an already “linked” remote control

When using a FB5 remote control:

- a. Press the Program button on the back of the FB5 remote control repeatedly till following blinking LED pattern on front of the FB5 remote controller is shown.
- b. Press STOP button shortly. The motor gives an confirmation that the “forget” mode is activated for a period of 10 seconds.

or

When using a Wall transmitter:

- a. Press the Program button on the back of the wall transmitter once.
- b. The LED next to Program button starts blinking slowly.
- c. Press the UP or the DOWN button of the wall transmitter for 5 seconds.
- d. When the UP or DOWN button is released, the motor gives an confirmation that the “forget” mode is activated for a period of 10 seconds.

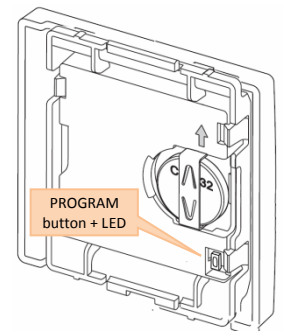
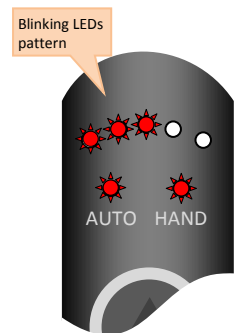

- 2) Now use the remote control you want the motor to forget (“unlink”)

When using a FB5 remote control:

- a. Press the STOP button of the FB5 remote control you want to forget shortly.
- b. The motor will give a double confirmation that this remote control is “unlinked” now.

or

When using a Wall transmitter:

- a. Press the UP or DOWN button of the Wall transmitter you want to forget for 5 seconds.
- b. The motor will give a double confirmation that this remote control is “unlinked” now.

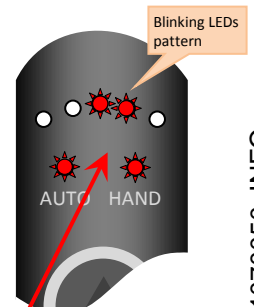

Forget sensor – VRS Luxsensor S

This procedure will “unlink” a VRS Luxsensor S from the motor.

1.1.1. Description

- 1) Activate the motor “forget” mode with an already “linked” remote control

Using a FB5 remote control:

- a. Press the Program button on the back of the FB5 remote control repeatedly till following blinking LED pattern on front of the FB5 remote controller is shown.
- b. Next, press DOWN button shortly till following blinking LED pattern on front of the FB5 remote controller is shown.

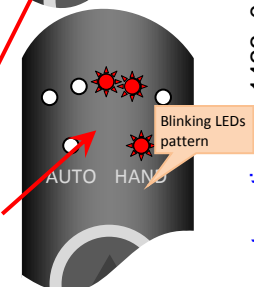

- c. Press STOP button shortly. The motor gives an confirmation that the “forget” mode is activated for a period of 10 seconds.
- 2) Now use the VRS Luxsensor S you want the motor to forget (“unlink”), press the Program button on the back of the VRS Luxsensor S once.
- 3) The motor will give a double confirmation that the VRS Luxsensor S is “unlinked” now.

Motor reset – FB5

Motor reset will erase the limit positions of the motor and will remove all “linked” remote controllers and sensors.

Preparation

The used FB5 remote control must be linked to the motor (see “Teach remote control - FB5”) and set to the correct channel.

Description

- 1) Press the Program button on the back of the FB5 remote control repeatedly till following blinking LED pattern on front of the FB5 remote controller is shown.
- 2) Press STOP button shortly. The motor gives an confirmation.
- 3) The motor limit positions are now reset and all “linked” remote controllers and sensors are removed.
- 4) The motor accepts “Remote Control Teach” messages for a period of 60 seconds.

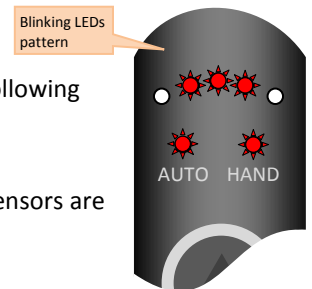

When no limit positions are set, the motor will react delayed on radio UP/DOWN commands (there will be a delay between pressing the switch and motor starts turning of 730 milliseconds). Also, the motor will have “dead man” behavior, meaning: as long as the UP or DOWN button is pressed on the remote, the motor runs, but as soon as you release the button, the motor stops.

Motor reset – Wall transmitter

Motor reset all will erase the limit positions and will clear all “linked” remote controllers and/or sensors.

Preparation:

The used wall transmitter (VRS Switch 1 / VRS Switch 2) must be linked to the motor (see “0 Teach remote control – Wall transmitter”).

Description

- 1) Press the Program button on the back of the wall transmitter for at least 5 seconds. The red LED next to the Program button starts blinking fast.
- 2) Press UP or DOWN button for at least 5 seconds continuously.
- 3) On release of the pressed button, a reset command is transmitted to the motor. The motor gives an confirmation.
- 4) The motor limit positions are now reset and all “linked” remote controllers and sensors are removed.
- 5) The motor accepts “Remote Control Teach” messages for a period of 60 seconds.

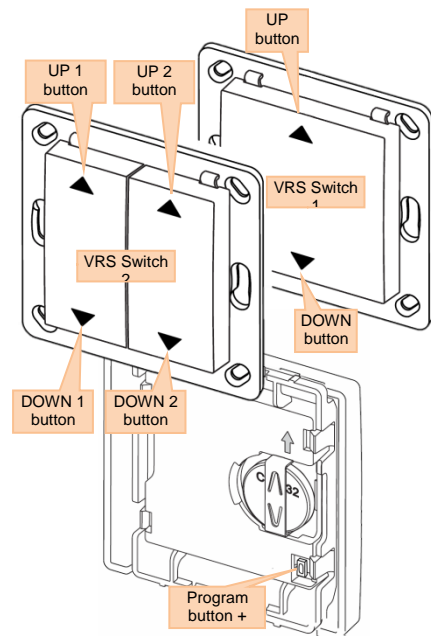

When no limit positions are set, the motor will react delayed on radio UP/DOWN commands (there will be a delay between pressing the switch and motor starts turning of 730 milliseconds). Also, the motor will have “dead man” behavior, meaning: as long as the UP or DOWN button is pressed on the remote, the motor runs, but as soon as you release the button, the motor stops.

Motor change direction – FB5 and Wall transmitter

When the motor reacts in opposite direction (when motor goes down when you press up and vice-versa), you need to change the motor direction. Motor direction can only be changed during installation phase, when no limit positions are set.

Preparation

The used remote control must be linked to the motor (see “0 Teach remote control”). The remote control is in standard operation mode (no LEDs are blinking).

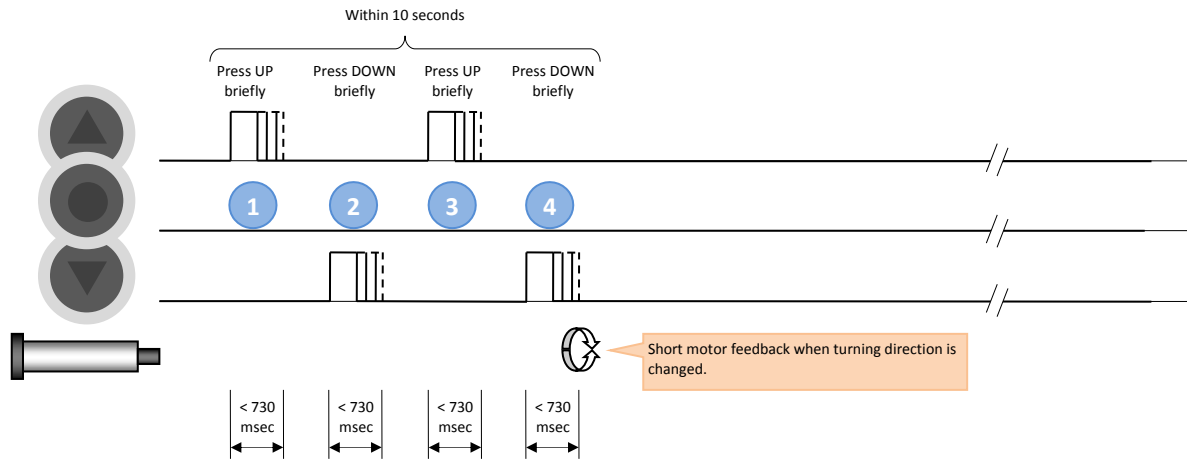

Description

- 1 ... 4 Press briefly (< 730 msec.) following sequence on the remote:
UP – DOWN – UP –DOWN
- Alternative sequence will also work:*
DOWN – UP – DOWN – UP briefly (< 730 msec.).

The complete sequence should be given within 10 seconds. The motor will give a confirmation feedback. Now, when operating the motor you will notice that the motor reacts in the correct direction in relation to your remote control (motor goes up when you press up on the remote and vice versa).

Setting upper virtual limit position – FB5 and Wall transmitter

This sequence will store the current motor position as a virtual upper limit position.

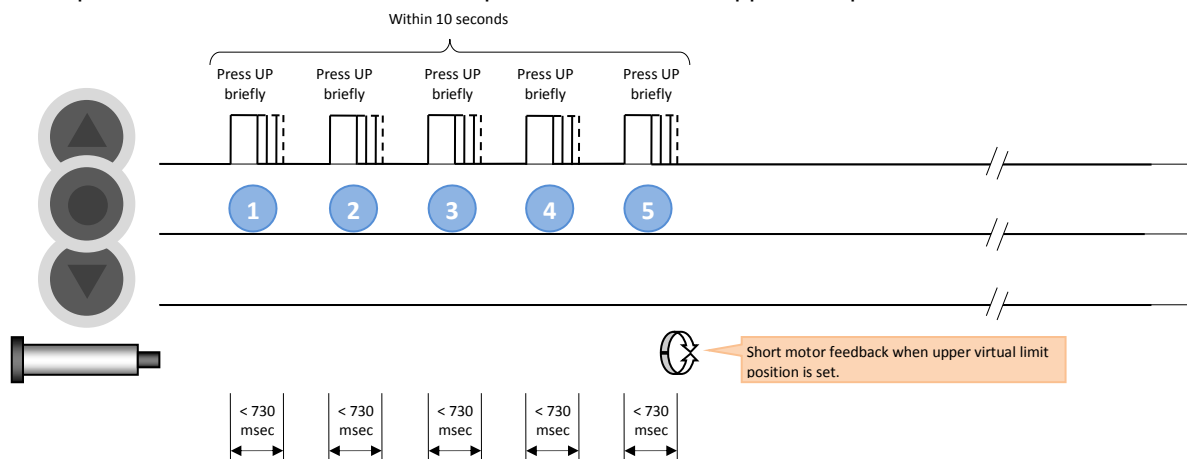

Description

- 1 ... 5 Press UP 5x briefly (shorter than 730 milliseconds).

After the 5th time, the limit position will be stored, the motor will give a confirmation. After setting the virtual upper limit position, it is not possible to steer the motor in UP direction behind this position.

Setting lower virtual limit position – FB5 and Wall transmitter

This sequence will store the current motor position as a virtual lower limit position.

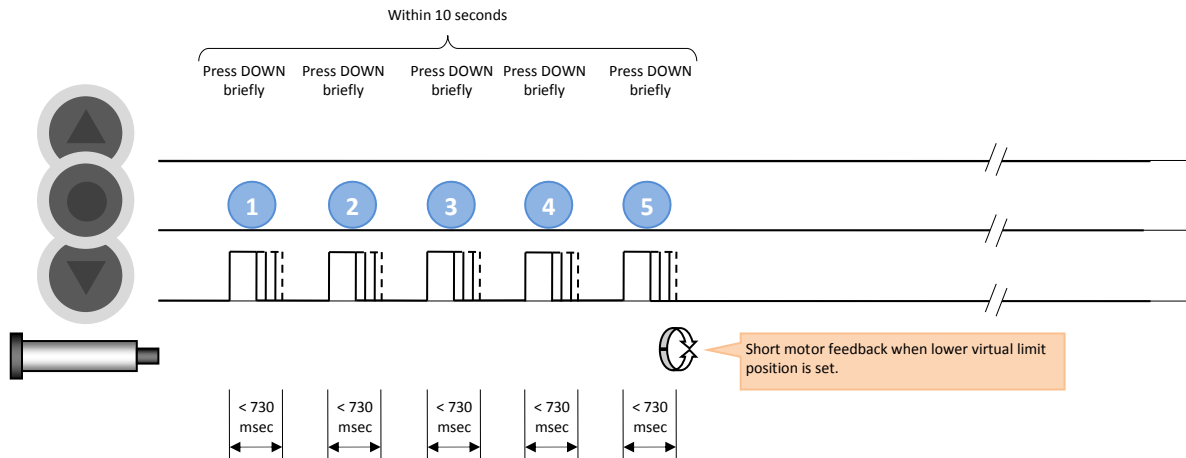

Description

1 ... 5 Press DOWN 5x briefly (shorter than 730 milliseconds).

After the 5th time, the limit position will be stored, the motor will give a conformation. After setting the virtual lower limit position, it is not possible to steer the motor in DOWN direction behind this position.

Setting intermediate position – only FB5

Preparation

1. The limit positions need to be set.
2. Steer the motor to the desirable intermediate position.

This sequence will store the current motor position as an intermediate position.

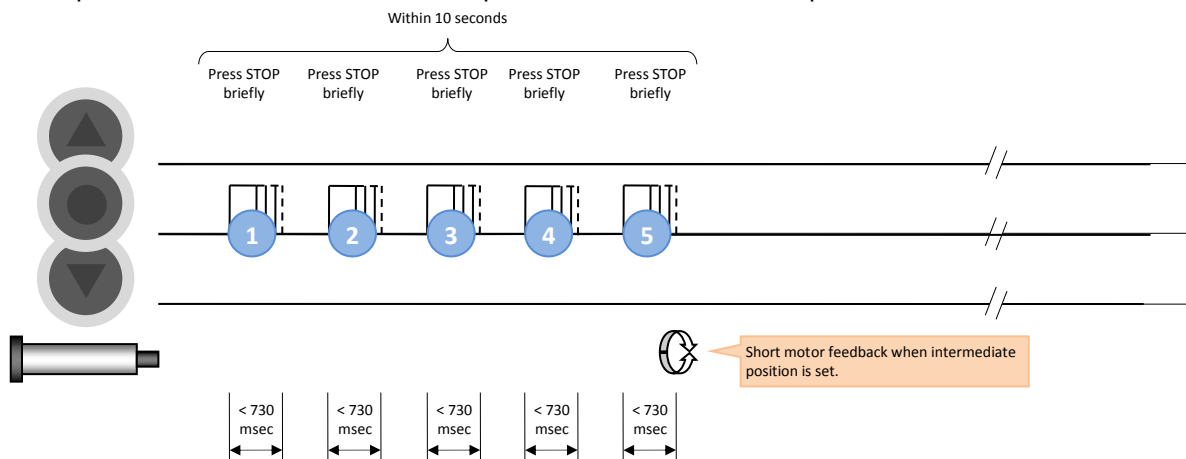

Description

1 ... 5 Press STOP 5x briefly (shorter than 730 milliseconds).

After the 5th time, the intermediate position will be stored, the motor will give a conformation.

Limitations

Only 1 intermediate position can be programmed.

Radio sensor

When an intermediate position is programmed, this position will be used as the “sun function active” position, meaning that when the sun function of the sun intensity sensor becomes active, the motor will go to this intermediate position.

Please pay attention that the sun shade product will not cover the sun intensity sensor when steered to the intermediate position.