

**SMI Bus**  
 Connecting cables, maximum total cable length: 350m  
 Connection topology: Free  
 Maximum SMI Drives: 16

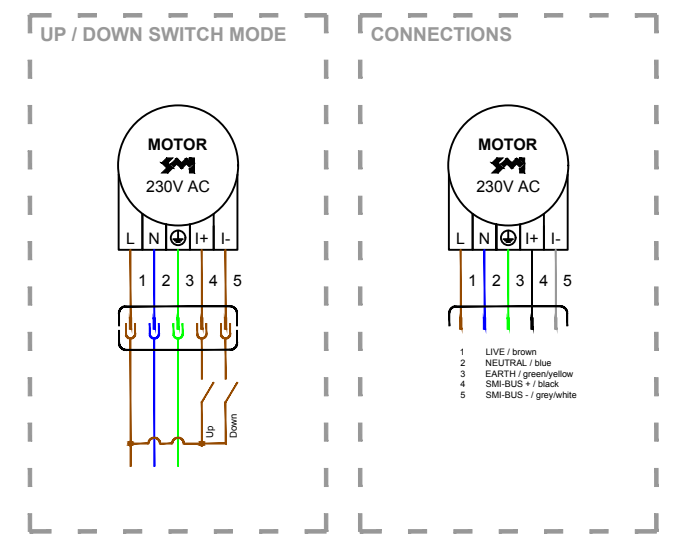

Project Name: <b>Vestamatic + CRE®</b> Solution Guide 8a	Drawing no.: SG8a.SMI 230 SM	Drawing produced by:  <b>Daren Whistler</b> Director +44 (0)7917 365 552 daren.whistler@vestamaticcre.com
	Rev: D	
Dwg Title: <b>SMI Motor Control</b> Switch Mode: 230V AC	Date: 23.03.2020	
	Print Size: A3	